

RIGOL

Service Guide

MSO2000A/DS2000A Series Digital Oscilloscope

**Oct. 2014
RIGOL Technologies, Inc.**

Guaranty and Declaration

Copyright

© 2014 RIGOL Technologies, Inc. All Rights Reserved.

Trademark Information

RIGOL is a registered trademark of RIGOL Technologies, Inc.

Publication Number

SGA18101-1110

Notices

- **RIGOL** products are covered by P.R.C. and foreign patents, issued and pending.
- **RIGOL** reserves the right to modify or change parts of or all the specifications and pricing policies at company's sole decision.
- Information in this publication replaces all previously corresponding material.
- Information in this publication is subject to change without notice.
- **RIGOL** shall not be liable for either incidental or consequential losses in connection with the furnishing, use or performance of this manual as well as any information contained.
- Any part of this document is forbidden to be copied, photocopied or rearranged without prior written approval of **RIGOL**.

Product Certification

RIGOL guarantees this product conforms to the national and industrial standards in China as well as the ISO9001:2008 standard and the ISO14001:2004 standard. Other international standard conformance certification is in progress.

Contact Us

If you have any problem or requirement when using our products or this manual, please contact **RIGOL**.

E-mail: service@rigol.com

Website: www.rigol.com

Safety Requirement

General Safety Summary

Please review the following safety precautions carefully before putting the instrument into operation so as to avoid any personal injury or damage to the instrument and any product connected to it. To prevent potential hazards, please use the instrument only specified by this manual.

Use Proper Power Cord.

Only the power cord designed for the instrument and authorized for use within the local country could be used.

Ground the Instrument.

The instrument is grounded through the Protective Earth lead of the power cord. To avoid electric shock, it is essential to connect the earth terminal of the power cord to the Protective Earth terminal before connecting any inputs or outputs.

Connect the Probe Correctly.

If a probe is used, do not connect the ground lead to high voltage since it has isobaric electric potential as the ground.

Observe All Terminal Ratings.

To avoid fire or shock hazard, observe all ratings and markers on the instrument and check your manual for more information about ratings before connecting the instrument.

Use Proper Overvoltage Protection.

Make sure that no overvoltage (such as that caused by a thunderstorm) can reach the product, or else the operator might be exposed to the danger of electrical shock.

Do Not Operate Without Covers.

Do not operate the instrument with covers or panels removed.

Do Not Insert Anything Into the Holes of Fan.

Do not insert anything into the holes of the fan to avoid damaging the instrument.

Use Proper Fuse.

Please use the specified fuses.

Avoid Circuit or Wire Exposure.

Do not touch exposed junctions and components when the unit is powered.

Do Not Operate With Suspected Failures.

If you suspect damage occurs to the instrument, have it inspected by **RIGOL** authorized personnel before further operations. Any maintenance, adjustment or replacement especially to circuits or accessories must be performed by **RIGOL** authorized personnel.

Keep Well Ventilation.

Inadequate ventilation may cause an increase of temperature or damage to the device. So please keep the instrument well ventilated and inspect the intake and fan regularly.

Do Not Operate in Wet Conditions.

In order to avoid short circuiting to the interior of the device or electric shock, please do not operate the instrument in a humid environment.

Do Not Operate in an Explosive Atmosphere.

In order to avoid damage to the device or personal injuries, it is important to operate the device away from an explosive atmosphere.

Keep Product Surfaces Clean and Dry.

To avoid the influence of dust and/or moisture in the air, please keep the surface of the device clean and dry.

Electrostatic Prevention.

Operate the instrument in an electrostatic discharge protective environment to avoid damage induced by static discharges. Always ground both the internal and external conductors of cables to release static before making connections.

Proper Use of Battery.

If a battery is supplied, it must not be exposed to high temperature or in contact with fire. Keep it out of the reach of children. Improper change of battery (note: lithium battery) may cause explosion. Use **RIGOL** specified battery only.

Handling Safety.

Please handle with care during transportation to avoid damage to buttons, knob interfaces and other parts on the panels.

Safety Terms and Symbols

Terms Used in this Manual. These terms may appear in this manual:



WARNING

Warning statements indicate conditions or practices that could result in injury or loss of life.



CAUTION

Caution statements indicate conditions or practices that could result in damage to this product or other property.

Terms Used on the Product. These terms may appear on the Product:

DANGER indicates an injury or hazard may immediately happen.

WARNING indicates an injury or hazard may occur.

CAUTION indicates potential damage to the instrument or other property might occur.

Symbols Used on the Product. These symbols may appear on the product:



Hazardous Voltage



Safety Warning



Protective Earth Terminal



Chassis Ground



Test Ground

Allgemeine Sicherheits Informationen

Überprüfen Sie die folgenden Sicherheitshinweise sorgfältig um Personenschäden oder Schäden am Gerät und an damit verbundenen weiteren Geräten zu vermeiden. Zur Vermeidung von Gefahren, nutzen Sie bitte das Gerät nur so, wie in diesem Handbuch angegeben.

Um Feuer oder Verletzungen zu vermeiden, verwenden Sie ein ordnungsgemäßes Netzkabel.

Verwenden Sie für dieses Gerät nur das für ihr Land zugelassene und genehmigte Netzkabel.

Erden des Gerätes.

Das Gerät ist durch den Schutzleiter im Netzkabel geerdet. Um Gefahren durch elektrischen Schlag zu vermeiden, ist es unerlässlich, die Erdung durchzuführen. Erst dann dürfen weitere Ein- oder Ausgänge verbunden werden.

Anschluss eines Tastkopfes.

Die Erdungsklemmen der Sonden sind auf dem gleichen Spannungspegel des Instruments geerdet. Schließen Sie die Erdungsklemmen an keine hohe Spannung an.

Beachten Sie alle Anschlüsse.

Zur Vermeidung von Feuer oder Stromschlag, beachten Sie alle Bemerkungen und Markierungen auf dem Instrument. Befolgen Sie die Bedienungsanleitung für weitere Informationen, bevor Sie weitere Anschlüsse an das Instrument legen.

Verwenden Sie einen geeigneten Überspannungsschutz.

Stellen Sie sicher, daß keinerlei Überspannung (wie z.B. durch Gewitter verursacht) das Gerät erreichen kann. Andernfalls besteht für den Anwender die Gefahr eines Stromschlages.

Nicht ohne Abdeckung einschalten.

Betreiben Sie das Gerät nicht mit entfernten Gehäuse-Abdeckungen.

Betreiben Sie das Gerät nicht geöffnet.

Der Betrieb mit offenen oder entfernten Gehäuseteilen ist nicht zulässig. Nichts in entsprechende Öffnungen stecken (Lüfter z.B.)

Passende Sicherung verwenden.

Setzen Sie nur die spezifikationsgemäßen Sicherungen ein.

Vermeiden Sie ungeschützte Verbindungen.

Berühren Sie keine unisolierten Verbindungen oder Baugruppen, während das Gerät in Betrieb ist.

Betreiben Sie das Gerät nicht im Fehlerfall.

Wenn Sie am Gerät einen Defekt vermuten, sorgen Sie dafür, bevor Sie das Gerät wieder betreiben, dass eine Untersuchung durch **RIGOL** autorisiertem Personal durchgeführt wird. Jedwede Wartung, Einstellarbeiten oder Austausch von Teilen am Gerät, sowie am Zubehör dürfen nur von **RIGOL** autorisiertem Personal durchgeführt werden.

Belüftung sicherstellen.

Unzureichende Belüftung kann zu Temperaturanstiegen und somit zu thermischen Schäden am Gerät führen. Stellen Sie deswegen die Belüftung sicher und kontrollieren regelmäßig Lüfter und Belüftungsöffnungen.

Nicht in feuchter Umgebung betreiben.

Zur Vermeidung von Kurzschluß im Geräteinneren und Stromschlag betreiben Sie das Gerät bitte niemals in feuchter Umgebung.

Nicht in explosiver Atmosphäre betreiben.

Zur Vermeidung von Personen- und Sachschäden ist es unumgänglich, das Gerät ausschließlich fernab jedweder explosiven Atmosphäre zu betreiben.

Geräteoberflächen sauber und trocken halten.

Um den Einfluß von Staub und Feuchtigkeit aus der Luft auszuschließen, halten Sie bitte die Geräteoberflächen sauber und trocken.

Schutz gegen elektrostatische Entladung (ESD).

Sorgen Sie für eine elektrostatisch geschützte Umgebung, um somit Schäden und Funktionsstörungen durch ESD zu vermeiden. Erden Sie vor dem Anschluß immer Innen- und Außenleiter der Verbindungsleitung, um statische Aufladung zu entladen.

Die richtige Verwendung des Akku.

Wenn eine Batterie verwendet wird, vermeiden Sie hohe Temperaturen bzw. Feuer ausgesetzt werden. Bewahren Sie es außerhalb der Reichweite von Kindern auf. Unsachgemäße Änderung der Batterie (Anmerkung: Lithium-Batterie) kann zu einer Explosion führen. Verwenden Sie nur von **RIGOL** angegebenen Akkus.

Sicherer Transport.

Transportieren Sie das Gerät sorgfältig (Verpackung!), um Schäden an Bedienelementen, Anschlüssen und anderen Teilen zu vermeiden.

Sicherheits Begriffe und Symbole

Begriffe in diesem Guide. Diese Begriffe können in diesem Handbuch auftauchen:



WARNING

Die Kennzeichnung WARNING beschreibt Gefahrenquellen die leibliche Schäden oder den Tod von Personen zur Folge haben können.



CAUTION

Die Kennzeichnung Caution (Vorsicht) beschreibt Gefahrenquellen die Schäden am Gerät hervorrufen können.

Begriffe auf dem Produkt. Diese Bedingungen können auf dem Produkt erscheinen:

- DANGER** weist auf eine Verletzung oder Gefährdung hin, die sofort geschehen kann.
- WARNING** weist auf eine Verletzung oder Gefährdung hin, die möglicherweise nicht sofort geschehen.
- CAUTION** bedeutet, dass eine mögliche Beschädigung des Instruments oder anderer Gegenstände auftreten kann.

Symbole auf dem Produkt. Diese Symbole können auf dem Produkt erscheinen:



**GefährlicheS
pannung**



**Sicherheits-
Hinweis**



Schutz-erde



Gehäusemasse



Erde

Document Overview

Format Conventions in this Manual:

1. Key

The function keys at the front panel are denoted by the format of "Button Name (Bold) + Text Box". For example, **Utility** denotes the "Utility" key.

2. Menu

The menu items are denoted by the format of "Menu Word (Bold) + Character Shading". For example, **System** denotes the "System" menu item under **Utility**.

3. Operation Step

The next step of operation is denoted by an arrow "→". For example, **Utility** → **System** denotes pressing **Utility** at the front panel and then pressing **System**.

Content Conventions in this Manual:

MSO2000A/DS2000A series includes the following models.

Model	Analog Bandwidth	Number of Analog Channels	Number of Signal Source Channels	Number of Digital Channels
MSO2072A	70 MHz	2	--	16
MSO2072A-S	70 MHz	2	2	16
MSO2102A	100 MHz	2	--	16
MSO2102A-S	100 MHz	2	2	16
MSO2202A	200 MHz	2	--	16
MSO2202A-S	200 MHz	2	2	16
MSO2302A	300 MHz	2	--	16
MSO2302A-S	300 MHz	2	2	16
DS2072A	70 MHz	2	--	--
DS2072A-S	70 MHz	2	2	--
DS2102A	100 MHz	2	--	--
DS2102A-S	100 MHz	2	2	--
DS2202A	200 MHz	2	--	--
DS2202A-S	200 MHz	2	2	--
DS2302A	300 MHz	2	--	--
DS2302A-S	300 MHz	2	2	--

User Manuals of this Product:

The user manuals of this product include the Quick Guide, User's Guide, Programming Guide, Data sheet and etc. For the latest version of the desired manual, download it from www.rigol.com.

Contents

Guaranty and Declaration	I
Safety Requirement	II
General Safety Summary.....	II
Safety Terms and Symbols	IV
Allgemeine Sicherheits Informationen.....	V
Sicherheits Begriffe und Symbole	VII
Document Overview.....	VIII
Chapter 1 Disassemble and Assemble	1-1
Disassemble and Assemble Notices	1-1
Exploded View of the Device	1-2
To Disassemble the Rear Cover	1-4
To Disassemble the Rear Metal Cover	1-5
To Disassemble the Fan	1-7
To Disassemble the Power Module	1-8
To Disassemble the Front Panel and Knobs	1-9
To Disassemble the Keyboards.....	1-10
To Disassemble the LCD.....	1-11
To Disassemble the Top Keys.....	1-12
To Disassemble the Main Board	1-13
Assemble Procedures.....	1-14
Chapter 2 Troubleshooting&Maintenance	2-1
Troubleshooting	2-1
Maintenance	2-3
System Maintenance	2-3
Warranty.....	2-3
General Care and Cleaning.....	2-4
Environmental Considerations	2-4

Chapter 1 Disassemble and Assemble

Disassemble and Assemble Notices

Notices:

- Do not disassemble the instrument unless for working requirement.
- Only authorized personnel can disassemble the instrument.
- Cut off the power supply before disassembling the instrument.
- Please wear anti-static wrist strap or make other anti-static precaution when disassembling the instrument.
- Please use proper tools and follow the correct steps.
- Take care not to deform the metal structure and be scuffed when disassembling the metal structures.

Tools Required:

- Phillips screwdriver T10
- BNC socket
- 5mm hexagon socket



WARNING

Make sure that the power supply is cut off before disassembling the instrument. Only personnel with relative training or relative qualification certification can disassemble the instrument.

Exploded View of the Device

You need to get a basic understanding of the main parts of the instrument before disassembling and assembling the instrument. When disassembling or assembling the instrument, please follow the procedures and avoid scratching the part surface. This manual mainly introduces the disassemble and assemble methods of MSO2000A/DS2000A series digital oscilloscope. The exploded view of MSO2000A/DS2000A (take MSO2000A-S as an example) is as shown in Figure 1-1.

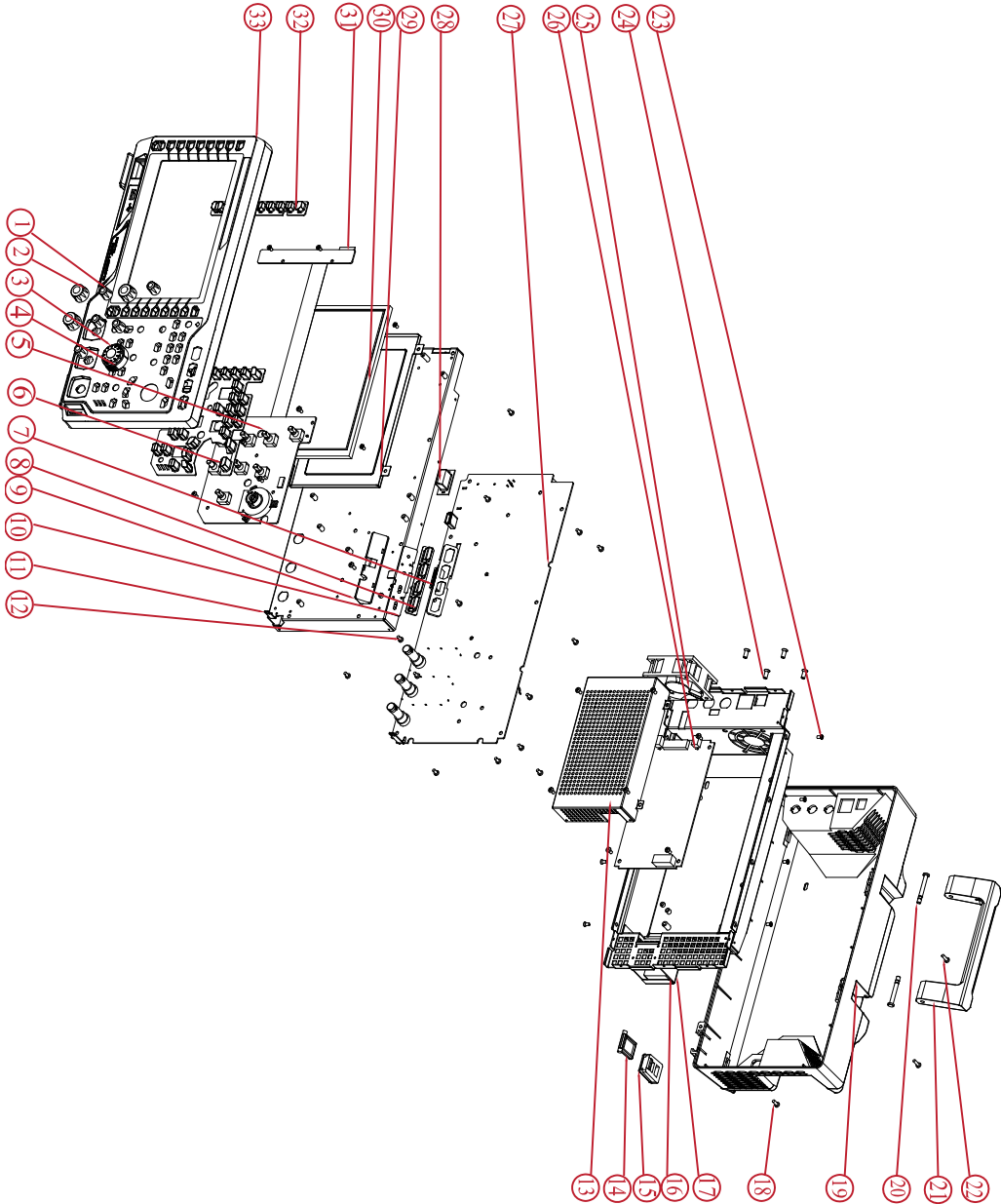

Figure 1-1 Exploded View of MSO2000A/DS2000A

Table 1-1 Part Explanation of MSO2000A/DS2000A Exploded View

No.	Part Name	No.	Part Name
①	Small Knob	⑱	Torx Pan Head Screw Assembly #PM/SW/FW3*8
②	Large Knob	⑲	Rear Cover
③	Inner Knob	⑳	Handle Rotating Shaft
④	Outer Knob	㉑	Handle
⑤	Keyboard	㉒	Torx Pan Head Screw #FM3*10
⑥	Main Keys	㉓	Torx Pan Head Screw #FM3*4
⑦	Top Key Presser	㉔	Torx Countersunk Head Self Tapping Screw #PTF5*10
⑧	Top Keys	㉕	Fan
⑨	Top Keys Supporting Block	㉖	Power Board
⑩	Top Keyboard	㉗	Main Board
⑪	Front Metal Plate	㉘	Power Key
⑫	Torx Pan Head Screw Assembly #PM/SW/FW3*6	㉙	LCD Frame
⑬	Power Shield	㉚	LCD
⑭	Supporting Leg	㉛	Left Keyboard
⑮	Non-slip Pad	㉜	Keys at the Left Side of the Screen
⑯	Power Socket	㉝	Panel
⑰	Rear Plate	--	--

The recommended disassemble procedures are as follows:

To Disassemble the Rear Cover → To Disassemble the Rear Metal Cover → To Disassemble the Fan → To Disassemble the Power Module → To Disassemble the Front Panel and Knobs → To Disassemble the Keyboards → To Disassemble the LCD → To Disassemble the Top Keys → To Disassemble the Main Board

To Disassemble the Rear Cover

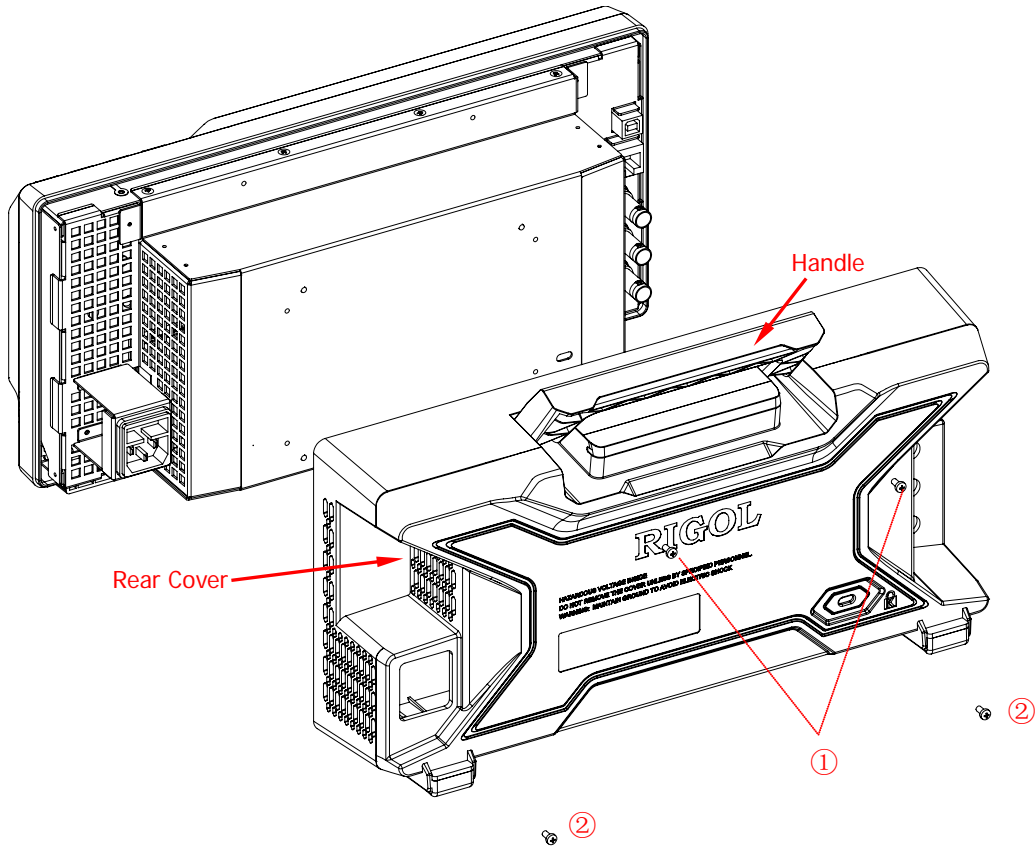

Figure 1-2 To Disassemble the Rear Cover

Part Explanations:

- ① 2 screws (torx pan head screw #FM3*10, one on each side) at the handle groove.
- ② 2 screws (torx pan head screw assembly #PM/SW/FW3*8, one at the inner side of the left and right supporting legs respectively) at the bottom of the cover.

Disassemble Steps:

1. Remove the 2 screws (①) at the handle groove using the screwdriver (T10).
2. Remove the 2 screws (②) at the supporting legs at the bottom of the cover using the screwdriver (T10).
3. Take off the rear cover gently.

To Disassemble the Rear Metal Cover

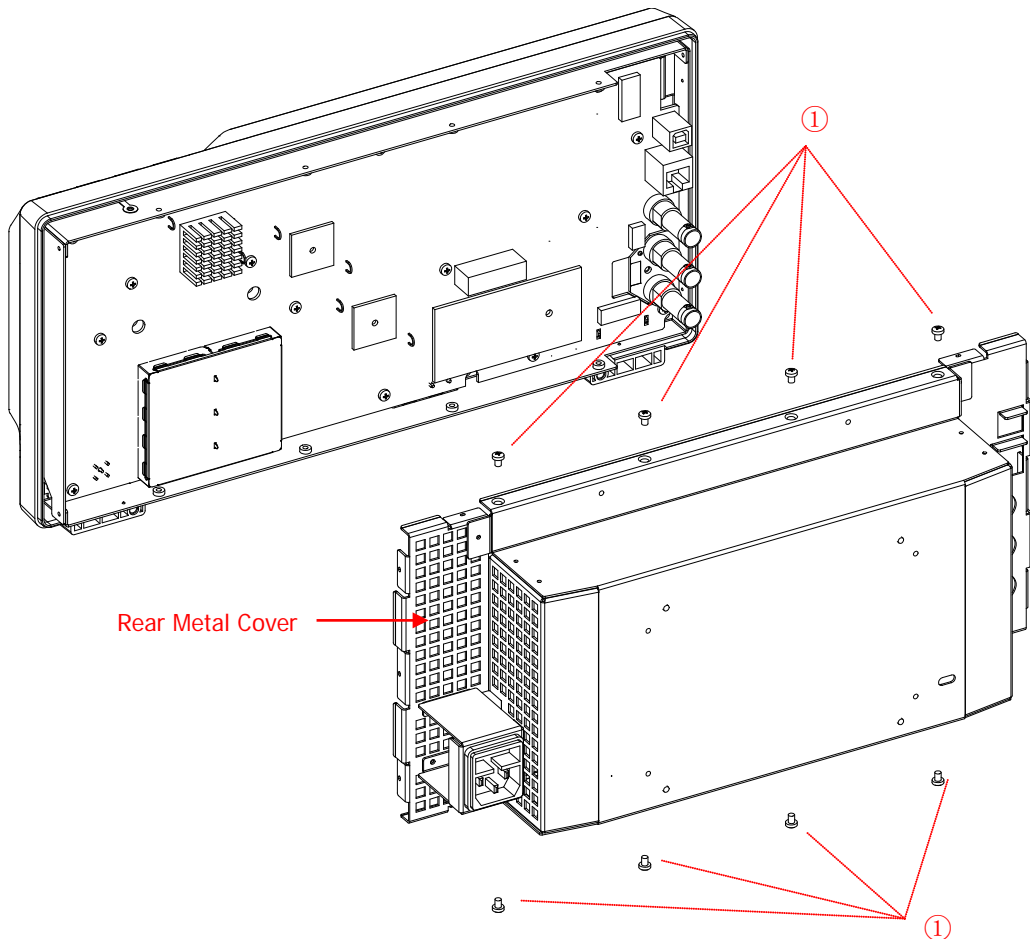

Figure 1-3 To Disassemble the Rear Metal Cover

Part Explanation:

- ① 8 screws (torx Pan head screw #FM3*4, 4 on the top and bottom respectively) fixing the front metal plate and rear metal cover.

Disassemble Steps:

1. Remove the 8 screws (①) fixing the front metal plate and rear metal cover using the screwdriver (T10).
2. Remove the AC power cable connected to the main board. Then, take off the rear metal cover gently.

Tip

- Pay attention to the connecting position of the AC power cable before removing it to avoid incorrect connection or incomplete connection when assembling the instrument.
- Insert the cable to the corresponding port on the main board before assembling the rear metal cover.

To Disassemble the Fan

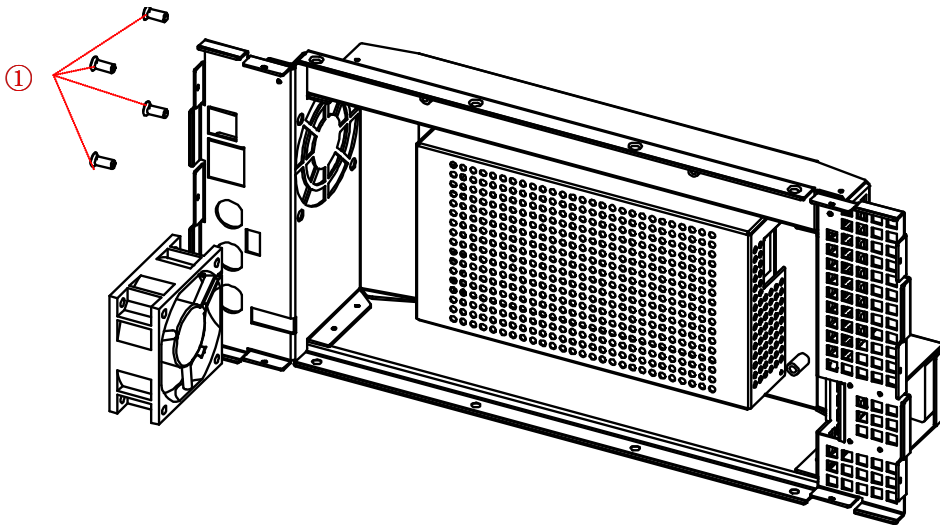

Figure 1-4 To Disassemble the Fan

Part Explanation:

- ① 4 screws (torx countersunk head self tapping screw #PTF5*10) fixing the fan.

Disassemble Steps:

1. Remove the 4 screws (①) fixing the fan using the screwdriver (T10).
2. Take off the fan gently.

Tip

- When assembling the fan, pay attention to its direction.
- You can remove the fan cable from the corresponding port after disassembling the power shield.

To Disassemble the Power Module

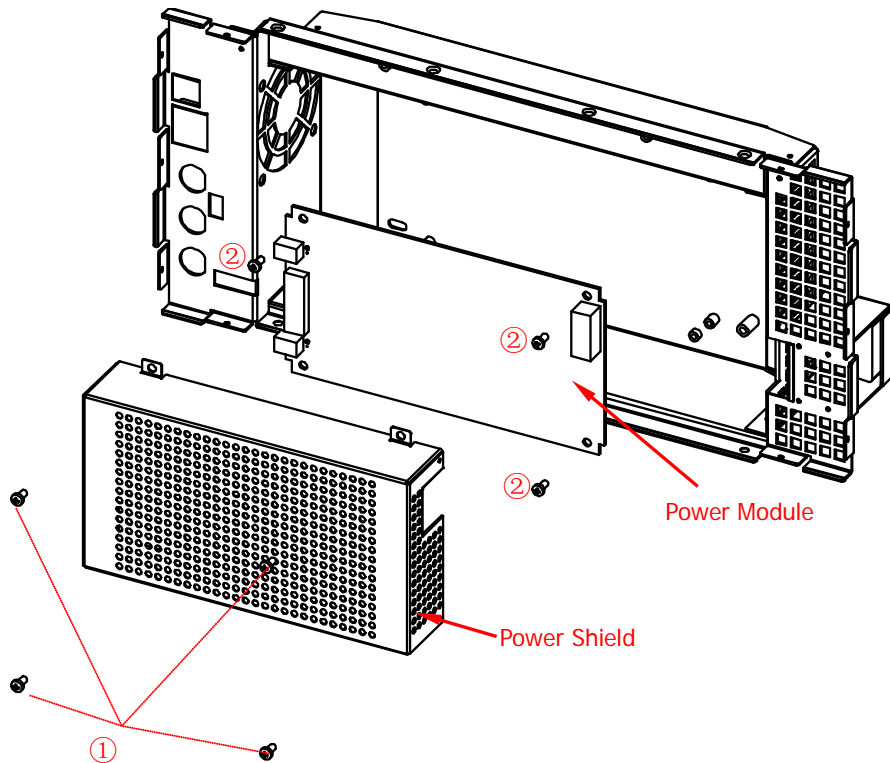

Figure 1-5 To Disassemble the Power Module

Part Explanations:

- ① 4 screws (torx pan head screw assembly #PM/SW/FW3*6) fixing the power shield.
- ② 4 screws (torx pan head screw assembly #PM/SW/FW3*6) fixing the power module (note: one of the screws is not marked out in the figure above).

Disassemble Steps:

1. Remove the 4 screws (①) fixing the power shield using the screwdriver (T10).
2. Remove the 4 screws (②) fixing the power module using the screwdriver (T10).
3. Remove the power cable and fan cable from the corresponding ports.

Tip

Pay attention to the connecting positions of the power cable and fan cable before removing them to avoid incorrect connection or incomplete connection when assembling the instrument.

To Disassemble the Front Panel and Knobs

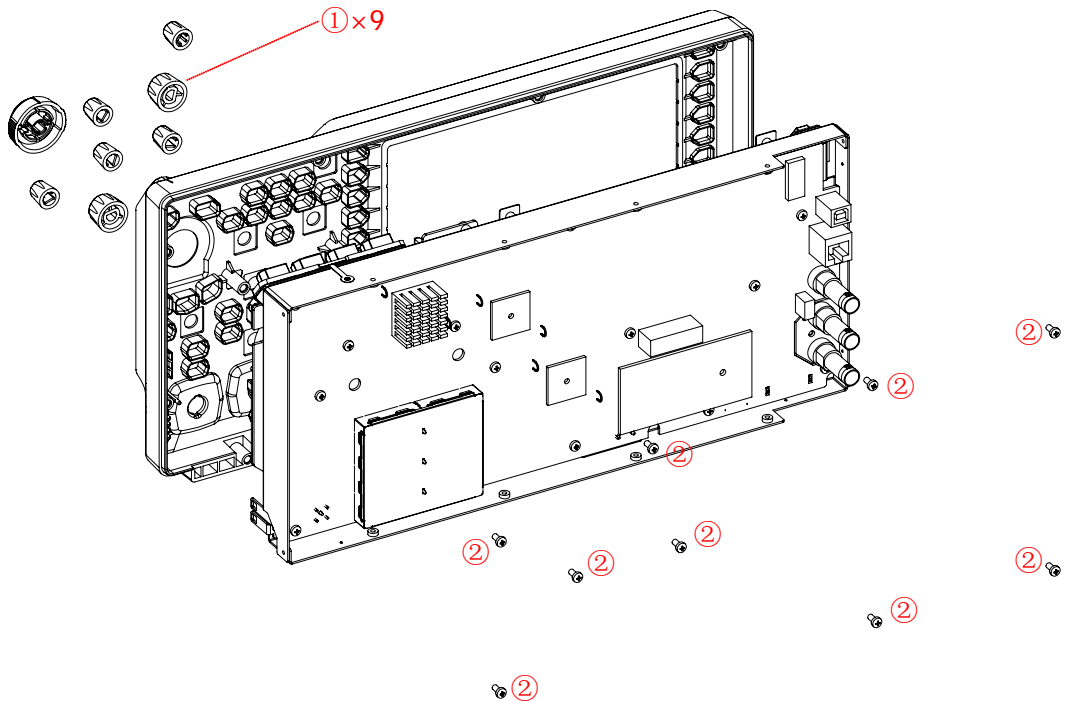

Figure 1-6 To Disassemble the Front Panel and Knobs

Part Explanations:

- ① 9 knobs.
- ② 9 screws (torx pan head screw assembly #PM/SW/FW3*6) fixing the front panel.

Disassemble Steps:

1. Remove the 9 (①) knobs.
2. Remove the 9 screws (②) fixing the front panel using the screwdriver (T10).
3. Take off the front panel gently.

Tip

It is recommended that you use a lever-like tool to pry out the knob when disassembling the knob and place a soft pad at the force bearing point to avoid damaging the key film and knob.

To Disassemble the Keyboards

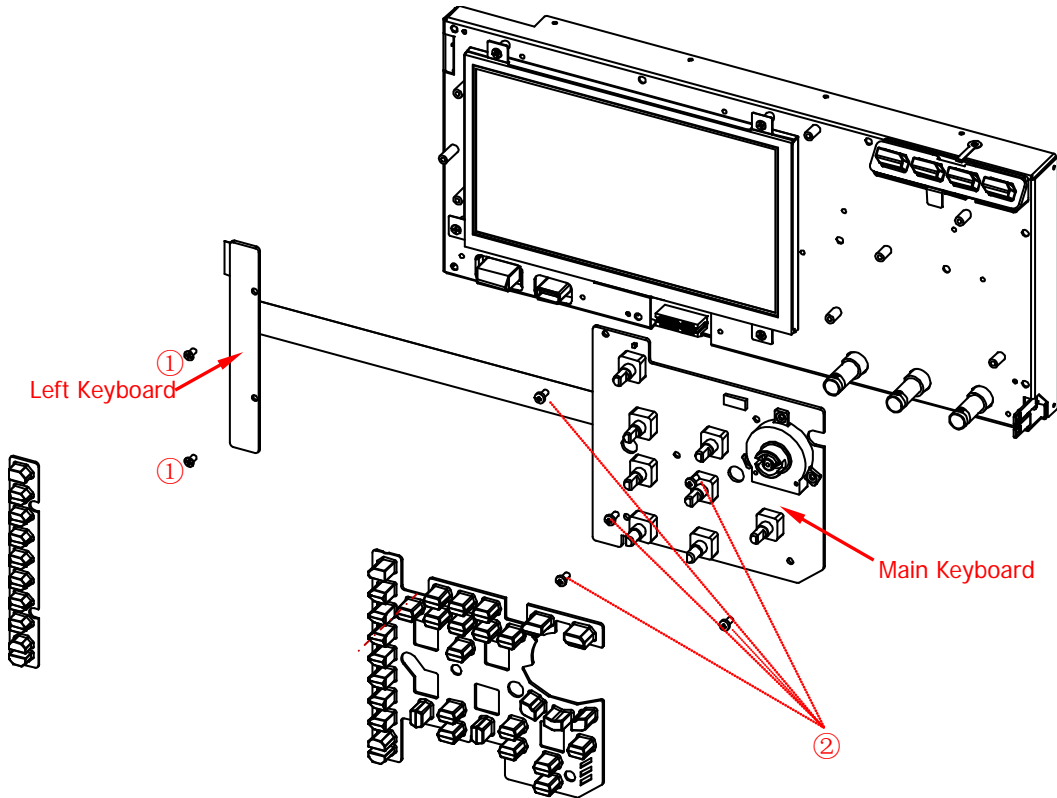

Figure 1-7 To Disassemble the Keyboards

Part Explanations:

- ① 2 screws (torx countersunk head screw #FM3*6) fixing the left keyboard.
- ② 5 screws (torx pan head screw assembly #PM/SW/FW3*6) fixing the main keyboard.

Disassemble Steps:

1. Remove the 2 screws (①) fixing the left keyboard using the screwdriver (T10).
2. Remove the 5 screws (②) fixing the main keyboard using the screwdriver (T10).
3. Remove the left keyboard cable connected to the main board and the top key cable connected to the main keyboard.

Tip

Connect the main keyboard cable to the corresponding port on the left keyboard and pass the left keyboard cable through the corresponding hole on the front metal plate when assembling the instrument.

To Disassemble the LCD

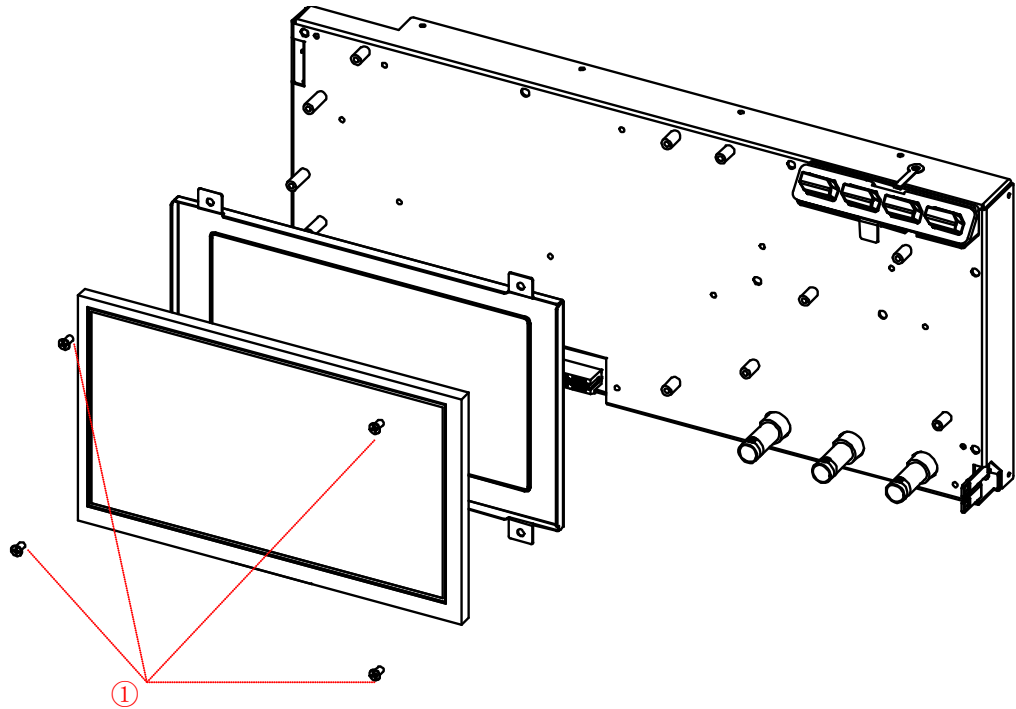

Figure 1-8 To Disassemble the LCD

Part Explanation:

① 4 screws (torx countersunk head screw #FM3*6) fixing the LCD.

Disassemble Steps:

1. Remove the 4 screws (①) fixing the LCD using the screwdriver (T10).
2. Remove the screen line connected to the main board.

To Disassemble the Top Keys

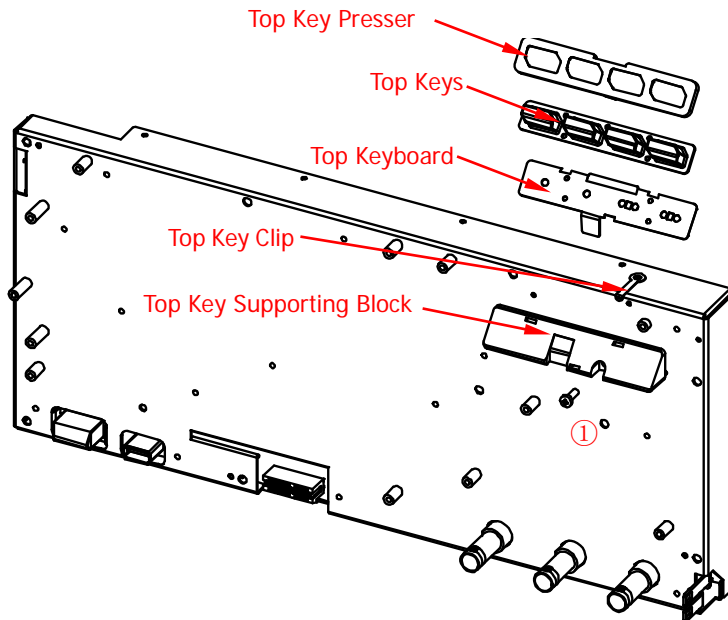

Figure 1-9 To Disassemble the Top Keys

Part Explanation:

- ① 1 screw (torx pan head screw assembly #PM/SW/FW3*8) fixing the top key supporting block.

Disassemble Steps:

1. Remove the top key clip soldered onto the top keyboard.
2. Remove the top key presser, top keys and top keyboard in sequence.
3. Remove the screw (①) fixing the top key supporting block using the screwdriver (T10).

To Disassemble the Main Board

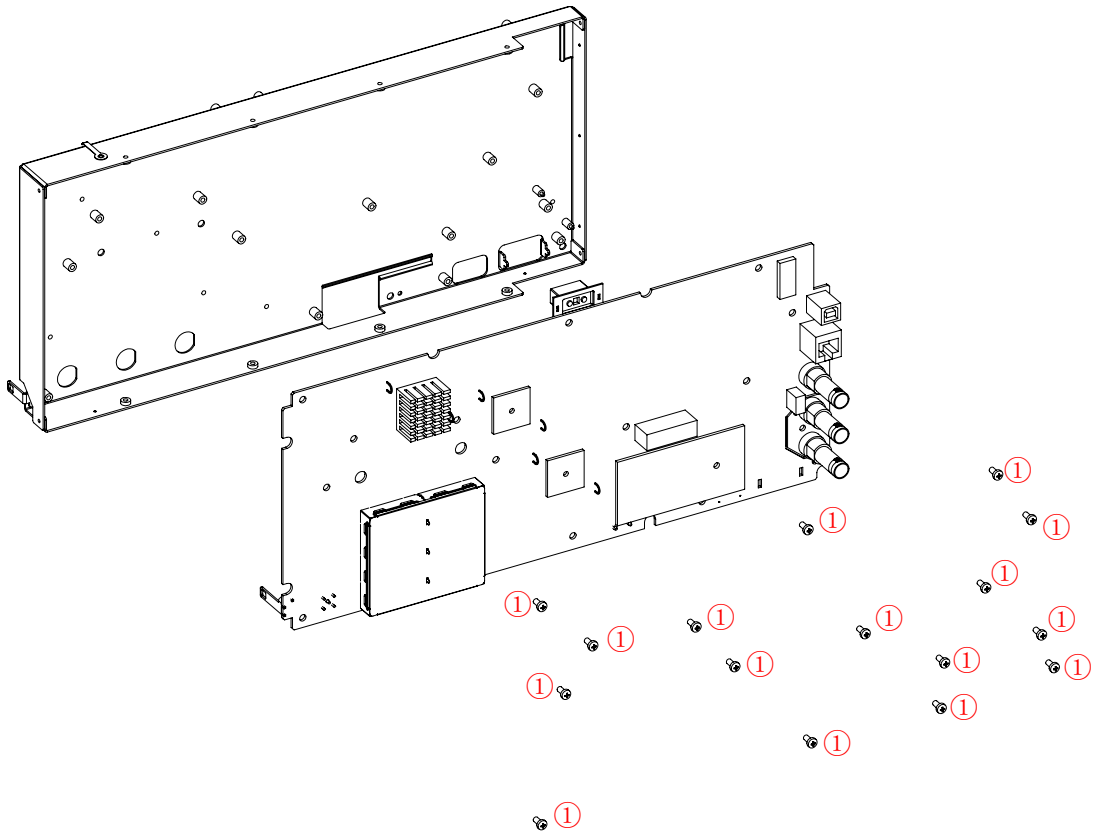

Figure 1-10 To Disassemble the Main Board

Part Explanation:

- ① 16 screws (torx pan head screw assembly #PM/SW/FW3*6) fixing the main board and front metal plate.

Disassemble Steps:

1. Remove the 3 nuts and washers at the BNC ports on the front metal plate using the BNC socket and 5mm hexagon socket.
2. Remove the 16 screws (①) fixing the main board and front metal plate using the screwdriver (T10).
3. Take off the main board gently.

Tip

When assembling the main board, pass the left keyboard cable and screen line through the corresponding holes on the front metal plate, fasten the main board and then insert the cables to the corresponding positions.

Assemble Procedures

The assemble procedures are the reverse of the disassemble procedures. Check whether the cables are correctly connected and whether all the screws are installed after each step of assemble.

You are recommended to follow the order and methods introduced above when disassembling and assembling the instrument to avoid damage to the instrument due to improper operation and to save your time.

Chapter 2 Troubleshooting&Maintenance

Troubleshooting

The commonly encountered failures and their solutions are listed below. When you encounter those problems, please solve them following the corresponding steps. If the problem remains still, please contact **RIGOL** and provide your device information (**Utility** → **System** → **System Info**).

1. The screen is still dark (no display) after pressing the power key:

- (1) Check whether the power switch is really on.
- (2) Check whether the power is correctly connected.
- (3) Check whether the fuse is burned out. If the fuse needs to be changed, please use the specified fuse.
- (4) Restart the instrument after finishing the above inspections.
- (5) If it still does not work correctly, please contact **RIGOL**.

2. The signal is sampled but no waveform of the signal is displayed:

- (1) Check whether the probe is correctly connected to item to be tested.
- (2) Check whether there are signals generated from the item to be tested (you can connect the probe compensation signal to the problematic channel to determine which has problem, the channel or the item to be tested).
- (3) Resample the signal.

3. The tested voltage amplitude is greater or lower than the actual value (this problem usually occurs when probe is used):

Check whether the probe ratio of the channel complies with the attenuation ratio of the probe.

4. There is waveform display but not stable:

- (1) Check the trigger source: press **MENU** → **Source** in the trigger control area (TRIGGER) at the front panel to check whether the trigger source selected complies with the signal channel actually used.
- (2) Check the trigger type: general signals should use "Edge" trigger and video signal should use "Video" trigger. Only when the proper trigger type is used, can the waveform be displayed stably.
- (3) Check the trigger level: adjust the trigger level to the middle of the signal.
- (4) Change the trigger holdoff setting.

5. No display after pressing **RUN/STOP:**

Check whether the trigger mode in the trigger control area (TRIGGER) at the front panel is "Normal" or "Single" and whether the trigger level exceeds the waveform range. If yes, set the trigger level to the middle or set **MODE** to "Auto".

Note: Using **AUTO** could automatically finish the above setting.

6. The display of waveform is ladder-like:

- (1) The horizontal time base might be too low. Increase the horizontal time base to increase the horizontal resolution and improve the display.
- (2) If the display type is "Vectors", the lines between the sample points may cause ladder-like display. Press **Display** → **Type** to set the display type to "Dots" to solve the problem.

7. Fail to connect PC or PictBridge printer through USB:

- (1) Press **Utility** → **IO Setting** → **USB Device** to check whether the current setting matches the device currently connected.
- (2) Check whether the USB cable is correctly connected to the oscilloscope and PC.
- (3) Check whether the USB cable is in good condition. If needed, restart the oscilloscope.

8. The USB storage device cannot be recognized:

- (1) Check whether the USB storage device can work normally.
- (2) Make sure that the USB storage device being used is flash storage type. This oscilloscope does not support hardware storage type.
- (3) Make sure whether the capacity of the USB storage device is too large. It is recommended that the capacity of the USB storage device being used with this oscilloscope is no larger than 8 GBytes.
- (4) Restart the instrument and then insert the USB storage device to check it.
- (5) If the USB storage device still cannot be used normally, please contact **RIGOL**.

Maintenance

System Maintenance

In order to ensure the performance and prolong the service life of the instrument, please follow the recommendations below.

1. Get a full understanding of the performance and basic operating method of the instrument before using it.
2. In order to ensure the measurement accuracy and the service life of the instrument, the instrument should be used and stored in places away from dust, shock, moisture, magnetic field and static; besides, the instrument should be placed in places where it will not be exposed to sunlight for long periods of time.
3. Do not operate the instrument when failure occurs. In this situation, you need to first solve the failure. Besides, regular test and calibration should be performed to ensure the accuracy of the performance.
4. Arrange the instrument properly after you finish the operation of the instrument.
5. Keep the relative accessories of the instrument properly for future use.

Warranty

RIGOL warrants that its products mainframe and accessories will be free from defects in materials and workmanship within the warranty period.

If a product is proven to be defective within the respective period, **RIGOL** guarantees the free replacement or repair of products which are approved defective. To get repair service, please contact with your nearest **RIGOL** sales and service office.

RIGOL does not provide any other warranty items except the one being provided by this summary and the warranty statement. The warranty items include but not being subjected to the hint guarantee items related to tradable characteristic and any particular purpose. **RIGOL** will not take any responsibility in cases regarding to indirect, particular and ensuing damage.

General Care and Cleaning

General Care

Do not store or leave the instrument where it may be exposed to direct sunlight for long periods of time.

Cleaning

Clean the instrument regularly according to its operating conditions. To clean the exterior surface, perform the following steps:

1. Disconnect the instrument from all power sources.
2. Clean the loose dust on the outside of the instrument with a lint-free cloth (with a mild detergent or water). When cleaning the LCD, take care to avoid scarifying it.



CAUTION

To avoid damage to the instrument, do not expose it to caustic liquids.



WARNING

To avoid injury resulting from short circuit, make sure the instrument is completely dry before reconnecting to a power source.

Environmental Considerations

The following symbol indicates that this product complies with the WEEE Directive 2002/96/EC.



Product End-of-Life Handling

The equipment may contain substances that could be harmful to the environment or human health. In order to avoid the release of such substances into the environment and harm to human health, we encourage you to recycle this product in an appropriate system that will ensure that most of the materials are reused or recycled appropriately. Please contact your local authorities for disposal or recycling information.